

JPE 8-2-2

# Design and Implementation of a Digital Control Unit for an Oxygenaire Servo Baby Incubator

Mohamed Zahran<sup>†</sup>, Mahmoud Salem\*, Yousry Attia\* and Aref Eliwa\*

<sup>†</sup>\*Electronics Research Institute, NRC Bldg., El-tahrir St., Dokki, 12311-Giza, Egypt

## ABSTRACT

This paper introduces a design and implementation of a digital control unit for an Oxygenaire Servo Baby Incubator. The control unit is designed and implemented according to international standards. The control unit is based on an AVR Atmel microcontroller unit. It is built for monitoring and control and displays the three main temperature values: set point temperature, baby skin temperature and air temperature. User friendly software is implemented. The implemented control unit was tested in the laboratory as well as in the field. The control unit is sensitive to change of 0.1°C. At startup, based on a unique control strategy, the incubator reaches its steady state in about 14 minutes. The system schematic diagrams are shown in the paper. Also, programs flow charts are presented.

The control unit was designed and implemented based on a contract between the Electronics Research Institute (ERI) and ENGIMED Company. The authors would like to thank ERI and ENGIMED for introducing all required finance and shoring to complete this work.

**Keywords:** Temperature control, Microcontroller, Thermistor, Baby incubator, Skin probe, Signal conditioning, Sensor transmitter

## 1. Introduction

Of all the advances that have taken place in the care of newborn babies none has had more impact than the realization that small babies need to be kept warm. Pre-term babies who are allowed to get cold are more likely to die. It is recognized that the thermal environment of the pre-term baby is one of the most important aspects of medical and nursing care. It is an area where obsessive attention to detail can pay dividends in terms of increased

survival and growth of small babies<sup>[1], [6], [8]</sup>. Thus, the incubator temperature control is an essential matter in the field of pre-term baby care<sup>[10]</sup>.

## 2. Heat Balance in a Newborn Baby

A baby's temperature is a balance between the heat which he produces himself and the heat which he loses. If the heat production and heat loss are exactly balanced, then this temperature is stable. If a baby loses more heat than it produces, his temperature will fall; if he produces more heat than he loses, his temperature will rise. It is, therefore, important in keeping babies warm to have some knowledge of how a baby gains and loses heat<sup>[7],[9],[11]</sup>.

Manuscript received Dec. 18, 2007; revised Jan. 21, 2008

<sup>†</sup>Corresponding Author: mbazahran\_2007@yahoo.com

Tel: +202-26225821, Electronics Research Institute

\*Electronics Research Institute, Egypt

A baby produces heat by metabolic activity. The various chemical reactions which occur in the cells of the body release energy as heat. A baby can lose heat in four ways:

- **Convection**, in which heat is lost to the air surrounding the baby,
- **Radiation**, in which a baby loses heat by radiating energy from his skin to all surroundings,
- **Evaporation**, in which a baby loses heat when water evaporates from his skin or his breath. Each 1 ml of water lost by evaporation removes about 600 calories of heat, and
- **Conduction**, in which a baby loses a small amount of heat by direct conduction to solid surfaces in contact with him.

### 2.1 The Need for an Incubator

When a baby's body temperature is stable, heat gain and heat loss are balanced. The safest and most pleasant way to keep a baby warm is to care for the baby clothed, wrapped and in cot. Incubators can provide a safe way of compensating for a baby's lost heat <sup>[1]</sup>.

### 2.2 Modes of Operation

Most of the standards recommend two modes of operation for baby incubators: air temperature mode and baby skin mode.

### 2.3 Air Temperature Mode

This mode has been widely used in the nursing care of newborns for many years. Its principle is simple; the baby lies on a mattress in a Perspex canopy. The air in the canopy is warmed by a heater and is continually circulated by a fan. The air temperature inside the canopy is controlled by a thermostat which is set by the nursing staff (incubator operator). Having decided that a baby requires care in an incubator, the nurse must choose an appropriate air temperature. The average temperature needed to provide a suitable thermal environment for a healthy naked baby cared for in an incubator is shown in Table 1.

### 2.4 Baby Skin Temperature Mode

The temperature sensor is a thermistor probe which is taped to the body's skin. It measures the baby's skin temperature rather than air temperature, so the heater

warms the air until the baby's skin reaches the set temperature. If the baby's skin temperature exceeds the set temperature then the power fed to the heater is reduced and the air temperature falls, allowing the baby to cool down, and vice versa to warm the baby up.

Table 2 show the suggested abdominal skin temperature setting for babies cared for in an incubator in baby skin temperature mode.

## 3. Features of the TCOSBI

Unlike <sup>[4]</sup>, the proposed TCOSBI has the following features:

- 1) The controller is based on the AVR Atmel AT90S8535 Micro controller system.
- 2) Large bright displays based on seven segments are easy to monitor and view from a distance.
- 3) A digital display system is provided to measure the infant temperature, air temperature and to set the required temperature.
- 4) A digital display system is provided to measure the enclosure humidity inside the incubator.
- 5) Feather touch keys are provided for easy operation.
- 6) A bar graph LED system is provided to indicate the heater output.
- 7) Fault indications and alarms are provided for:
  - Baby skin probe failure either short circuit or open circuit for incubators with both air and skin temperature controllers,
  - Baby skin probe failure as open circuit for incubators with either an air or a skin temperature controller (not both),
  - Air probe failure,
  - High temperature,
  - Low temperature,
  - High temperature cut off (independent hardware circuit),
  - Heater failure,
  - Fan failure, and
  - Power failure

The baby probe / air probe is made of a highly sensitive sensor which is interchangeable and does not need field calibration.

Table 1 Air Temperature

Birth-weight (kg)	35°C	34°C	33°C	32°C
1.0 - 1.5	For 10 days	After 10 days	After 3 weeks	After 5 weeks
1.5 - 2.0		For 10 days	After 10 days	After 4 weeks
2.0 - 2.5		For 2 days	After 2 days	After 3 weeks
Greater than 2.5			For 2 days	After 2 days

Table 2 baby skin temperature

Birth-weight (kg)	Abdominal skin temperature °C
Less than 1.0	36.9°C
1.0 - 1.5	36.7°C
1.5 - 2.0	36.5°C
2.0 - 2.5	36.3°C
Greater than 2.5	36.0°C

## 4. Hardware Description

### 4.1 Controller Subsystem Block Diagram

The system block diagram is shown in Fig. 1. Two input ports and a counter are used to monitor the incubator system variables.

The first input port is dedicated for analog input variables such as air temperature, baby skin temperature and humidity.

The second input port is dedicated for the keypad interface that has five keys classified as follows:

- Set key that enable the functionality of all the other keys,
- Up key that is used to increase the set temperature value (in set temperature mode)
- Down key that is used to decrease the set temperature value (in set temperature mode)
- Alarm key that is used for silencing and checking the alarm, and
- Mode key that is used to toggle between air and skin modes.

The third input variable is the fan speed that is conditioned as a stream of pulses counted by one of the microcontroller counters. The output ports are established to present the following:

- Displaying the measured variables air and baby skin and set point temperature values,
- Displaying the visual alarm signals for;
  - High temperature (HI TEMP),
  - Air flow (Air Flow) which refers to the fan operation,
  - Baby skin probe (SKIN PROBE) either short or open circuit failure, if the skin probe is not being used, the word "OFF" is written instead of displaying the baby skin temperature (upper left corner of the control panel),
  - Air temperature sensor (AIR SENSOR) either short or open circuit failure,
  - Low set temperature (Low SET TEMP) if the temperature in the incubator goes out of range during normal operation, that is, the set temperature value has not been changed,
  - High set temperature (HI SET TEMP), like low set temperature but for higher temperature,
  - Power failure (POWER FAIL) that indicates the failure of any of the different power supply channels for the electronic circuits and microcontroller cards.
- Displaying the mode of operation of the incubator either "AIR" or "SKIN" mode,
- Displaying the heater bar.

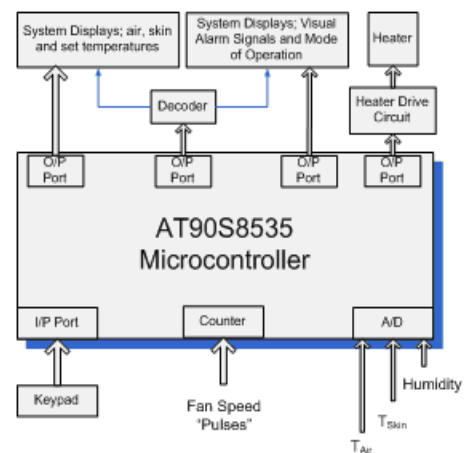

Fig. 1 Controller System Block Diagram

## 4.2 The Controller Features

The system heart control unit is the ATMEL ATmega8535 microcontroller. It is a low-power CMOS 8-bit microcontroller based on the enhanced RISC architecture. Most of the instructions are executed in one clock cycle. Though, ATmega8535 can execute 1 million instructions per second (1MIPS) per MHz. The device can operate up to 8MHz, so a high execution speed can be achieved with a single chip microcontroller unit.

## 4.3 System Control Flow Charts

The flow chart of the system controller is divided into the five main flow charts shown in figures 2-6. The software is written in assembly language. It consists of a main program and a number of subroutines. Each subroutine is used to do one of the following functions:

- temperature control function,
- A/D conversion function,
- display refresh function,
- keypad check function,
- fan fail function,
- number transformation function, and
- faults function.

The control routine is executed only every 2 sec, the fan fail routine is executed every 1 sec, and the display refresh interrupt routine is executed every 0.5 msec. The temperature degrees in the control range (from 22°C to 41°C) are stored in a lookup table as digital numbers in steps of 0.1°C. So, the microcontroller converts the actual temperature to a digital number via the A/D, and then it looks up the temperature degree corresponding to this number from the lookup table.

## 5. Incubator System Description

### 5.1 Body of the Incubator

The body of the incubator is shown in figure 7. The control panel is located on the front of the incubator where the nurse is staying for easy access to the keypad and monitoring of the display signals<sup>[5]</sup>.

### 5.2 Heater Temperature Control

As an alternative to phase control, the method of integral cycle control or burst-firing is used for heating



Fig. 2 body of the incubator and control panel

loads<sup>[2]</sup>. Here the switch is turned on for a time  $t_n$  with  $n$  integral cycles and turned off for a time  $t_m$  with  $m$  integral cycles.

As the Triac used here are turned-on at the zero-crossing of the input voltage and turned-off at zero current, supply harmonics and radio frequency interference are very low.

So, the heater temperature is controlled by the “Integral Cycle Control” technique. One (triac) is used to control the power flow from main to the heater, and its control signal is generated from the microcontroller according to the required power percentage that has been calculated. The period ( $T$ ) is divided into two sections: in the first section ( $n$ ) the power is applied to the heater; in the second section ( $m$ ) the power is switched off as shown in figure 8 and figure 9. The power rating is 400W, supplied from 220V AC supply, 50Hz. The output voltage:

$$V_o = V_s \sqrt{k},$$

Where:

$k$  is the duty cycle

$$\left( k = \frac{n}{n+m} = \frac{n}{T} \right), \text{ and}$$

$V_s$  is the rms value of main voltage.

This project was mainly undertaken to improve the performance of the old ENGIMED Company incubator system. It was necessary to decrease the settling time (it was about 45 min.) and to minimize the over and undershoot values.

In the new system, a triac is used to control the power

flow from the main to the heater and the triac control signal is generated from the microcontroller according to the required power. The heater temperature is controlled by "Integral Cycle Control" technique, in which, the triac is turned on for a time  $T_{on}$  with  $n$  integral cycles and turned off for a time  $T_{off}$  with  $m$  integral cycles. So, the period  $T$  is divided into two sections: in the first section,  $n$ , the power is applied to the heater; in the second section,  $m$ , the power is switched off as shown in Fig. 8 and Fig. 9.

The following empirical equation is suggested to calculate the  $T_{on}$  period:

$$T_{on} = T_{on} + k_1 (T_{ref} - T_{act}) - k_2 (T_{act} - T_{acto}) \quad (1)$$

Where:

- $k_1$  &  $k_2$  are constants
- $T_{ref}$  is the required temperature set point
- $T_{act}$  is the actual temperature of air/skin
- $T_{acto}$  the previous actual temperature of air/skin

Based on this equation the system performance is greatly improved.

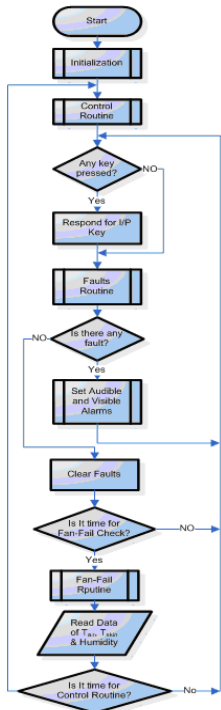

Fig. 3 The Main Program Flowchart

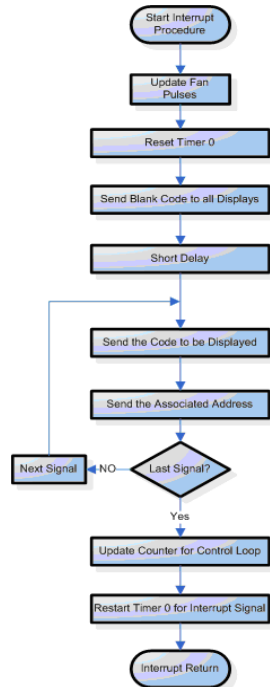

Fig. 4 The Display Signals Interrupt Subroutine Flowchart

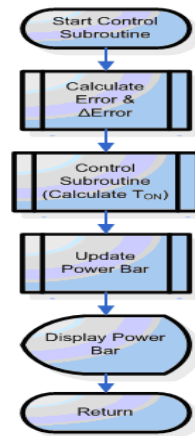

Fig. 5 Control Signal Flowchart

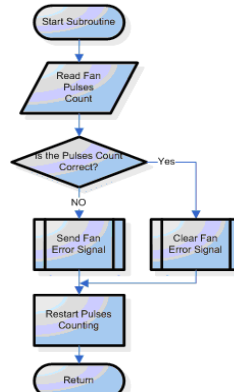

Fig. 7 Fan-Fail subroutine Flowchart

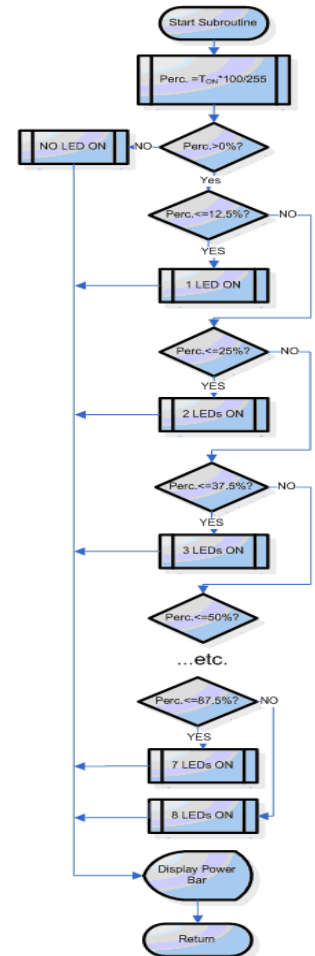

Fig. 6 Power Bar Subroutine Flowchart

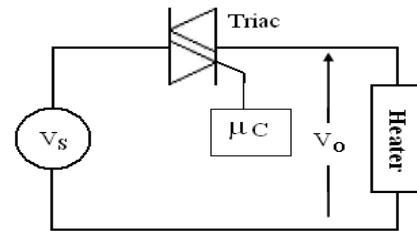

Fig. 8 power circuit of heater

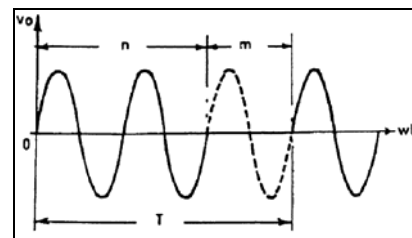

Fig. 9 Integral Cycle Control Waveform

### 5.3 Fan Speed Sensor

The fan speed sensor is a permanent magnet with a coil which acts as a pulse generator. It looks like a single coil generator. A piece of permanent magnet is fixed on the fan blade (mechanical stability is considered) while the coil is fixed on the body of the incubator in the front of coil. The output signal is a semi-sine wave signal with a positive half cycle only. A signal conditioning circuit based on the zero crossing detectors technique is implemented for enhancing the shaped signal for possible counting (monitoring) with the help of one of the built-in microcontroller counters and timers.

### 5.4 Air Temperature, Skin Probe and Humidity Sensors

The box of sensors is shown in the following figure. Three sensors are indicated in the box: air temperature sensor (thermistor), baby skin probe and humidity sensor. The box is located in the appropriate location in the incubator to reflect the actual values of the system variables: air and skin temperatures and humidity level. Of course the skin probe is taped to the body of the baby in the place that is determined by the nurse.

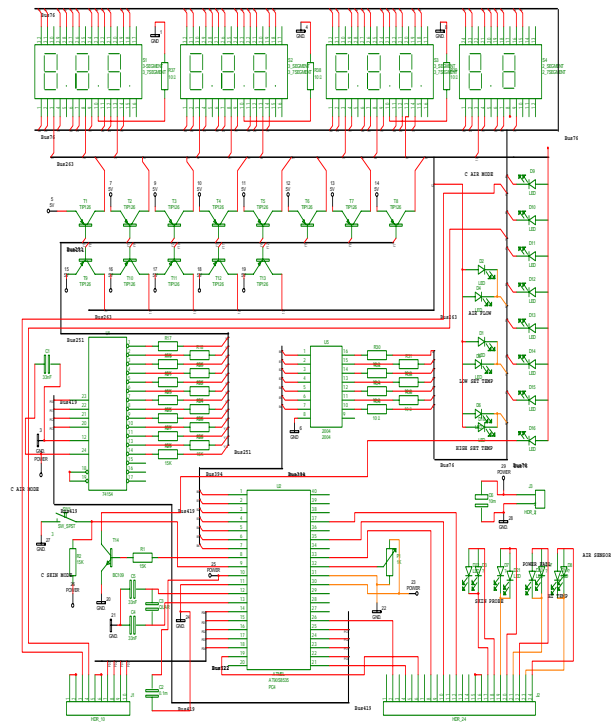
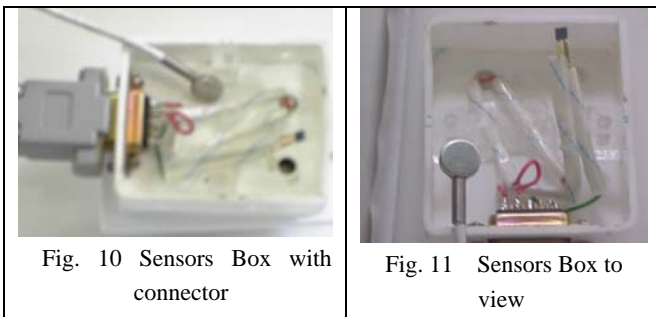

Fig. 12 Schematic diagram of Microcontroller and Display Card

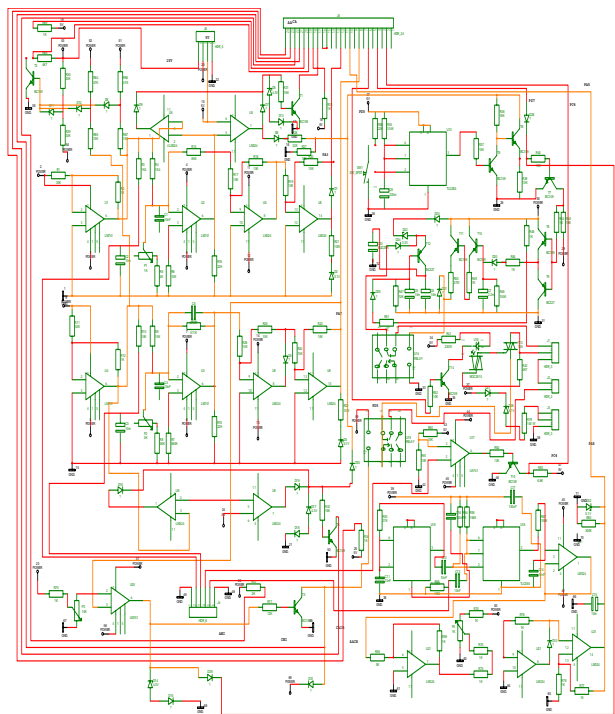

Fig. 13 Schematic diagram of signal conditioning circuit's card

### 5.5 Schematic Diagrams and Circuit Design

The schematic diagrams of the TCOSBI are introduced in four separate circuits illustrated as follows:

1. Schematic diagram for the microcontroller and display card, Fig. 12,
2. Schematic diagram for the signal conditioning card, Fig. 13,
3. Schematic diagram for the keypad card, Fig. 14, and
4. Schematic diagram for the power supply card, Fig. 15.

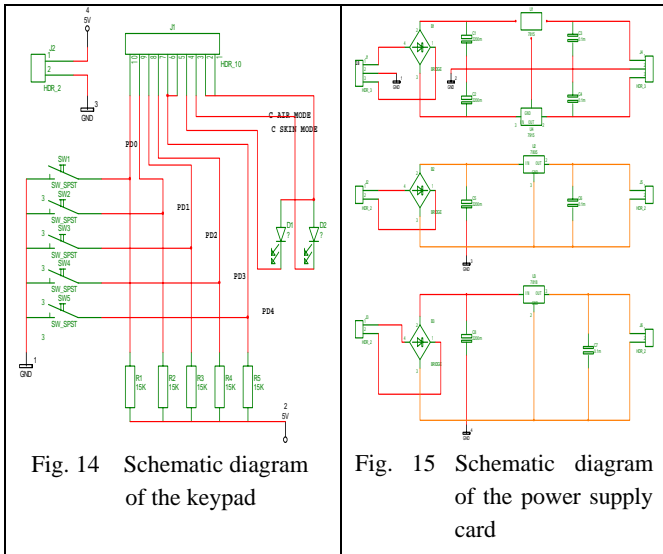

Fig. 14 Schematic diagram of the keypad

Fig. 15 Schematic diagram of the power supply card

Fig. 16 Housing of the PCB cards

**5.6 PCB Cards**

The printed circuit boards contain four separate cards for the four separate schematic diagrams. The PCB cards are assembled in the housing shown in Fig. 16. Fig. 17, 18 shows the PCB cards while they are interfaced together and with the incubator as they are in operation.

**5.6.1 Front Panel Display Card**

The front panel shows the three main temperature values: set point temperature (target temperature), air temperature and baby skin temperature. Based on the mode of operation, either the air temperature or the baby skin temperature should adjust to and maintain the set temperature value. The three temperature values are displayed in two digits and one decimal place. The accuracy of the set point and the measured and displayed air or baby skin temperature is 0.1 °C. The fourth seven segment display indicates the humidity as a percentage; it is displayed in only two digits from 00 to 99%. The power bar is also displayed on the front panel. It consists of eight LEDs; full brightness indicates the need for full power to accelerate the warming up of the incubator when it is turned on. The mode of incubator operation, either air or baby skin temperature mode, is also displayed on the front panel. The set of alarms are also displayed on the front panel. Details about the conditions and function of each alarm will be illustrated in place.

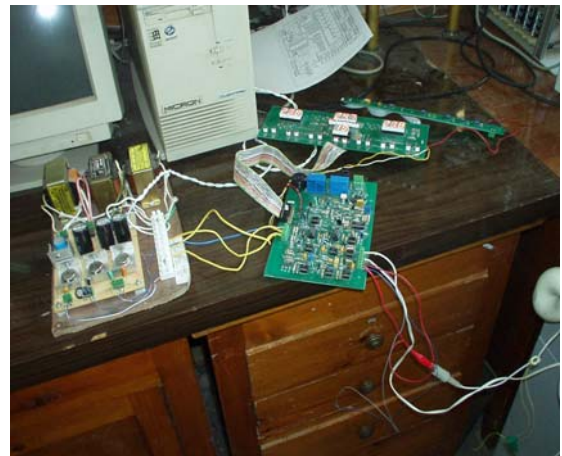

Fig. 17 the PCB cards, components side, interfaced together

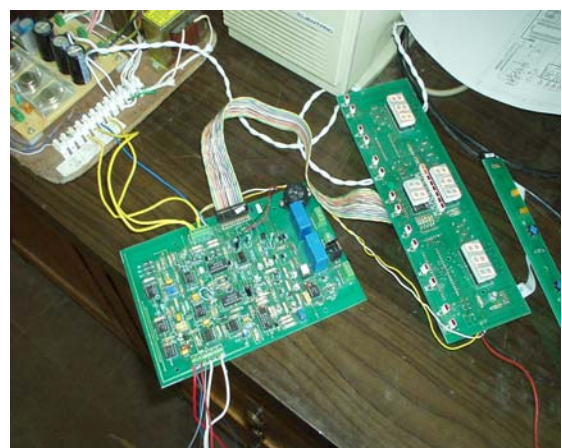

Fig. 18 the PCB cards, components side, interfaced together and working



Fig. 19 Front panel card

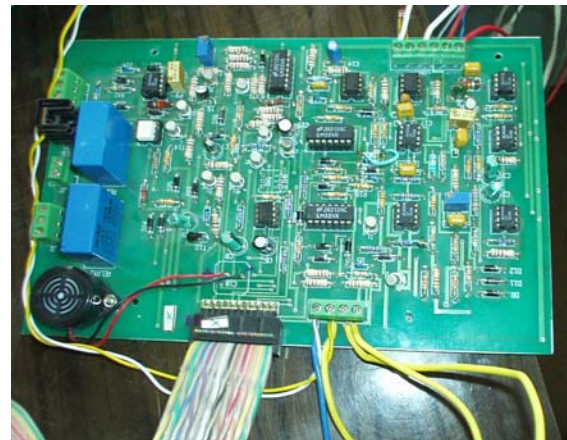

Fig. 21 SC Card before Assembly Card

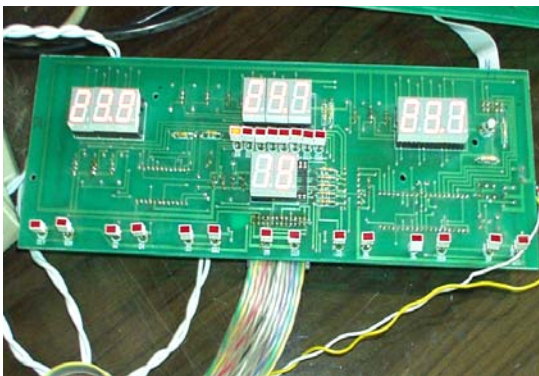

Fig. 20 Display Card, Seven Segments Side

### 5.6.2 SC Card and Display Card, Components Side

The signal conditioning card was complex because we built up all the transmitter and signal conditioning circuits needed to match the measured variables to the microcontroller requirements. Three signal conditioning circuits were built for the new incubator variables: air temperature, baby skin temperature and humidity. The conditioning circuits were designed and implemented with the help of operational amplifiers and the technology of circuits bridges usage. The bridges help the sensors to be more sensitive and amplify the signals. The PCBs were manufactured in Benha Electronics Factory. ENGIMED introduced the body of the incubator as shown in Fig. 2.

### 5.6.3 Power Supply Module

The power supply card consists of three independent channels, 5V for microcontroller and display card,  $\pm 12V$  for the operational amplifiers and the analog circuit's power supply and 18V for fan power supply.

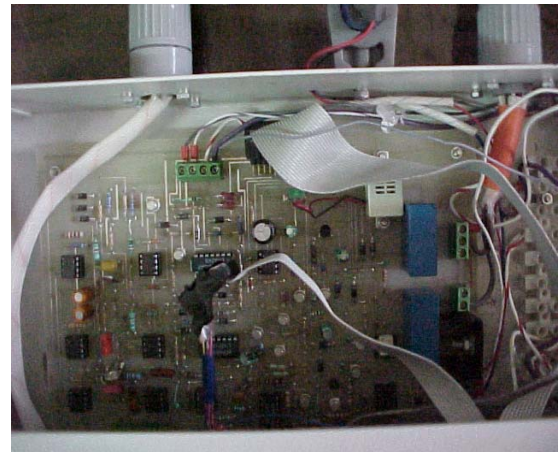

Fig. 22 Image of the implemented and interfaced signal conditioning circuits



Fig. 23 Signal Conditioning Circuits and Display Card, Components Side



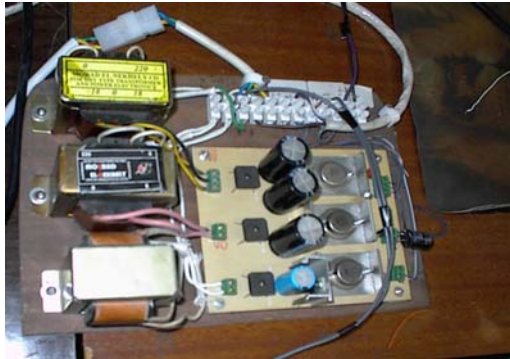

Fig. 24 Power Supply Card

#### 5.6.4 Keypad Card & Keys Functions

The keypad consists of five keys. The set key, left one, is the main key since none of the other keys will be active without pressing and holding this key first. This function is introduced to protect the system settings from being altered accidentally. To set the mode of operation, first you have to press the set key plus the mode key and hold them for several seconds to be sure that you mean to change the mode of operation from air to skin mode. The two LED's that display the mode of operation are included in the keypad card as illustrated in figures 25, 26.



Fig. 25 PCB of Keypad Card



Fig. 26 Part of Front Panel Showing Keypad

## 6. Test Results

The incubator with the implemented control unit was tested and approved by Cairo University staff according to international standards. The system settling time is about 14 min. and the overshoot and undershoot are limited to less than 1°C. The temperature control accuracy and the intelligent software used are the most important features of the system.

## 7. Conclusions

A fully digital and programmable temperature system was designed and implemented for the Oxygenaire Servo Baby Incubator. The transmitter circuits were also designed and implemented for all the variables of the incubator that are used as control signals like the air temperature sensor (thermistor), baby skin temperature sensor (probe), humidity sensor and air flow sensor. Two modes of operation are implemented in the control algorithm: air or skin mode.

The AVR microcontroller is used as a control device and the control program is developed using ATMEL assembly language programming. The controller has the capability to set the temperature value and control the incubator temperature according to the selected mode of operation. The accuracy of the temperature is 0.1°C, and the over or under shot temperature values match the international standards. The settling time of the temperature of this incubator is about 14 minutes; the old version of this incubator took 45 minutes to reach the settling time, while some incubators on the market now need up to 2 hours to get to the steady state mode of operation. The keypad is programmed to prevent any accidental changes to the system settings by requiring parallel pressing of two keys simultaneously.

The controller has an added feature that can check the running program at any time with the help of the audible discontinuous alarm when you press the set and alarm keys at the same time. A silent circuit is designed to stop the audible alarm during maintenance if necessary. The silent time is programmable and can be modified at any time. The system controller display is optimized to be seen from appropriate distance for easy monitoring. All the alarm signals are displayed in audible and visual ways.

## References

- [1] N. Rutter, M.D., M.R.C.P., "A Guide to Incubator Care of Infants", Vickers Medical Ltd (1995).
- [2] M.H. Rashid, "Power Electronics Handbook", Academic Press, San Diego, California, 2001.
- [3] Douglas V. Hall "Microprocessors and Interfacing programming and hardware", McGraw-hill Inc., 1992.
- [4] D4 Surgicals (INDIA) PVT. LTM., "Infant Incubator",

<http://www.d4-medical-surgicalequipments.com/medical-surgical-equipments.html#infant-incubator>,

- [5] COBAMS SRL, "Neonatal incubators", Via Cicogna 20, San Lazzaro Di Savena, Bologna Italy, Italy, <http://www.alibaba.com/company/10681037.html#companyprofile>
- [6] Sandra Lee Smith, "Heart Period Variability of Intubated Very-Low-Birth-Weight Infants during Incubator Care and Material Holding", AMERICAN JOURNAL OF CRITICAL CARE, Vol. 12, No.1, Jan. 2003.
- [7] Michael P. Meyer, Matthew J. Payton, Andrew Salmon, Chris Hutchinson and Alan de Klerk, "A Clinical Comparison of Radiant Warmer and Incubator Care for Preterm Infants From Birth to 1800 Grams", <http://www.pediatrics.org/cgi/content/full/108/2/395>, Copyright © 2001 by the American Academy of Pediatrics. All rights reserved. Print ISSN: 0031-4005. Online ISSN: 1098-4275
- [8] SAUDI Standard Organization, "Medical Electrical Equipment Part 2: Particular Requirements for Safety of Baby Incubators"
- [9] D. A. Ducker and N. Marshall, "Humidification without risk of infection in the Dräger Incubator 8000", [http://www.draeger.com/MT/internet/pdf/CareAreas/PerinatalCare/pc\\_incu\\_8000\\_humidity\\_book\\_en.pdf](http://www.draeger.com/MT/internet/pdf/CareAreas/PerinatalCare/pc_incu_8000_humidity_book_en.pdf)
- [10] Hannah Lieberman, "Incubator Baby Shows: A Medical and Social Frontier", <http://www.historycooperative.org/journals/ht/35.1/lieberman.html>, Vol. 35, Issue 1, June 2006.
- [11] Maciej K. Ginalski, Andrzej J. Nowak, Luiz C. Wrobel, "A combined study of heat and mass transfer in an infant incubator with an overhead screen", [http://bura.brunel.ac.uk/bitstream/2438/1701/1/Medical Engineering & Physics.pdf](http://bura.brunel.ac.uk/bitstream/2438/1701/1/Medical%20Engineering%20&%20Physics.pdf)



**Mohamed Bayoumy A. Zahran (M. Zahran)**, was born in Egypt, received his B.Sc from Kima High Institute of Technology, M.Sc in 1993 and Ph.D. in 1999 from Cairo University, Faculty of Engineering, Electrical Power and Machines

Dept. He is an Associate Professor Researcher at the Electronics Research Institute, Photovoltaic Cells Dept. His experience is mainly in the field of renewable energy sources, systems design, management and control. He has been employed full time by the National Authority for Remote Sensing and Space Science (NARSS) since 2002, Space Division as System Engineer of MisrSat-2 Project and Satellite Power Subsystem Designer.



**Mahmoud Mohamed A. M. Salem (M. Salem)** received the B.Sc. degree in Electrical Engineering in 1988 from Minofia University, Egypt. He received the M.Sc. and the Ph.D degrees in Electrical Engineering from Cairo University, Egypt in 1994 and 2000, respectively. Now, he is working as a researcher at the Electronics Research Institute, Cairo, Egypt. His research interests include artificial intelligence, neural networks, control systems, electrical drives, and digital controller hardware.



**Yousry Attia Abdel-gawad (Y. Attia)** received his B.Sc from the Electrical Power and Machines Dept., Munofia Univ., Faculty of Eng., Egypt in 1987, M.Sc in 1995 and Ph.D in 2001 from Cairo Univ., Faculty of Eng. Electrical power and Machines Dept., in the field of Power Electronics. He is currently a researcher in the Electronics Research Institute, Photovoltaic Cells Dept. His experience in the field includes working with renewable energy sources and systems design, management and control.



**Aref Yosef Eliwa (A. Eliwa)**, was born in Egypt in 1964, He received his B.Sc in Electrical Engineering from Zagazig University in 1987, and M.Sc in 1993 and Ph.D. in 2000 all from Faculty of Engineering, Ain Shams University. From 1989 -2003, he was a researcher at the Electronics Research Institute, Photovoltaic Cells Dept. where he conducted research on solar cell technology and applications. Currently he is a lecturer at the Telecommunication and Electronics Engineering Dept., faculty of Eng.